

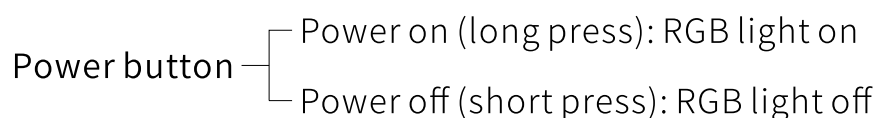

快速入门指南
Quick Start Guide
型号/Model: SA1

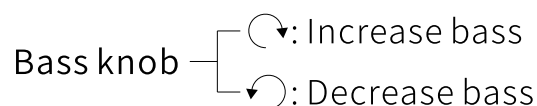

Input selection button and volume knob

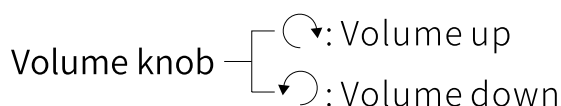
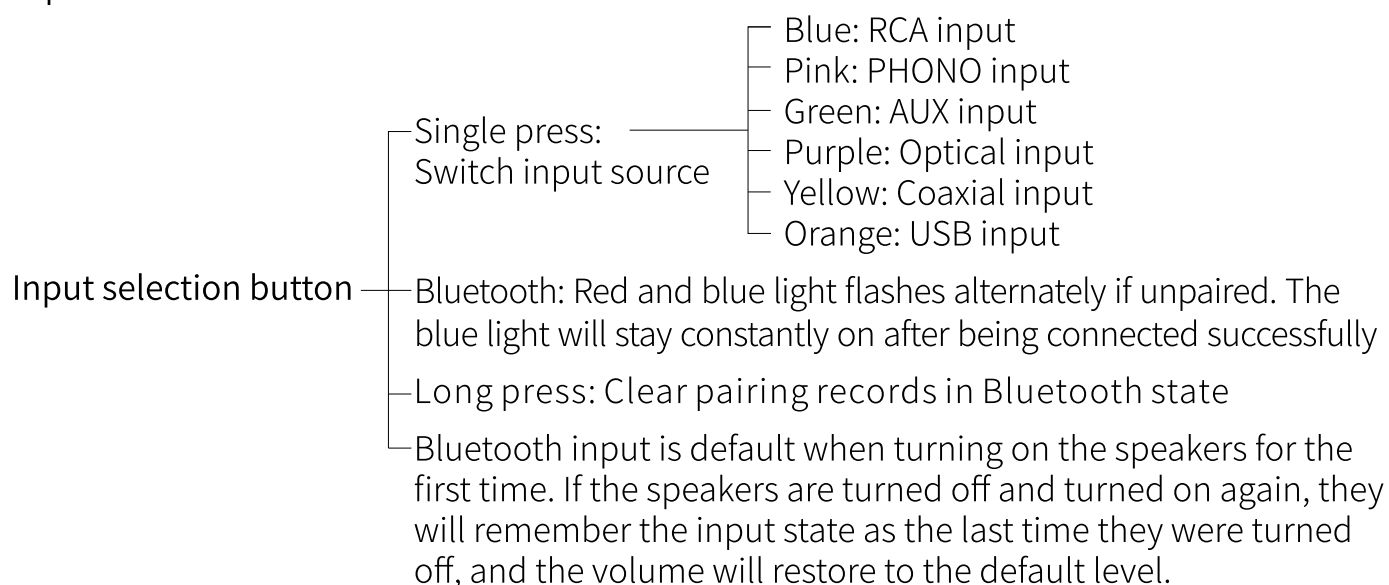

RCA/PHONO input switch

Through the RCA/PHONO input switch, you can switch between RCA input and PHONO input. By default, the switch is toggled to “RCA IN”. When connecting to a phono, set the switch to “PHONO” to switch to PHONO input, under which the RGB light will display in pink.

Bluetooth connection

Bluetooth input is default when turning on the speakers for the first time. The RGB light flashing alternately in red and blue means the speakers are in the pairing state. Search “FIIO SA1” on the device and connect them. After a successful connection, the RGB light will display in blue constantly.

Clear pairing: When the Bluetooth is connected, long press the Input selection button to disconnect Bluetooth and reenter the pairing state. The RGB light will flash alternately in red and blue.

Subwoofer connection

In different input states, the SA1 can be connected to an active subwoofer via the SUB OUT port to enhance the bass.

Automatically standby and wake up

Standby: The speakers will enter the standby state automatically if there is no input for 20 minutes with RGB light turning to red. After entering the standby state for 20 minutes, the RGB light will be off.

Wake up: It will automatically enter the playback state if there is any input, and the RGB light will restore the color state before standby.

Remote Control Explained

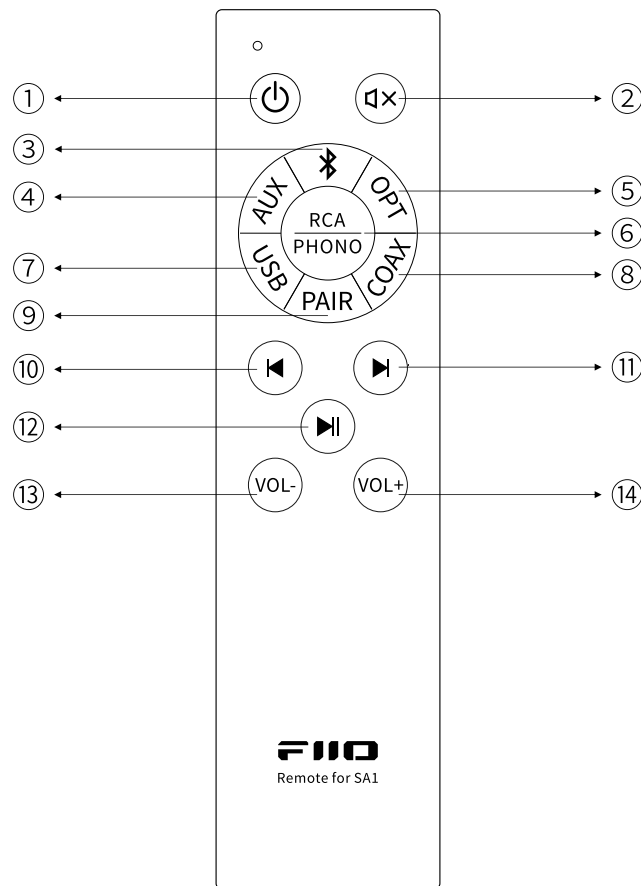

- | | | |
|-------------------|-------------------------------|---------------|
| ① Standby | ⑥ RCA/PHONO input | ⑪ Next track |
| ② Mute | ⑦ USB input | ⑫ Play/Pause |
| ③ Bluetooth input | ⑧ Coaxial input | ⑬ Volume down |
| ④ AUX input | ⑨ Bluetooth re-pairing button | ⑭ Volume up |
| ⑤ Optical input | ⑩ Previous track | |

RCA/PHONO input button

When the RCA/PHONO input switch is toggled to “RCA IN”, press the RCA/PHONO input button to switch to RCA input. When the RCA/PHONO input switch is toggled to “PHONO”, press the RCA/PHONO input button to switch to PHONO input.

Previous track/Next track/Play and Pause buttons

In Bluetooth and USB inputs, the remote control can be used to switch previous and next tracks, and play and pause.

Note: Pictures are for reference only. The actual product may vary.

Instructions for PEQ

The SA1 supports adjusting EQ on the mobile phone, choosing preset sound effects or customizing the desired effect. Here are the instructions on how to use it:

1. Download the FIIO Control APP on the app market or scan the QR code below.
2. After downloading the APP, connect the device to the SA1, enter the FIIO Control APP and select the SA1 to connect them.
3. Go to the equalizer page after a successful connection, as shown below.

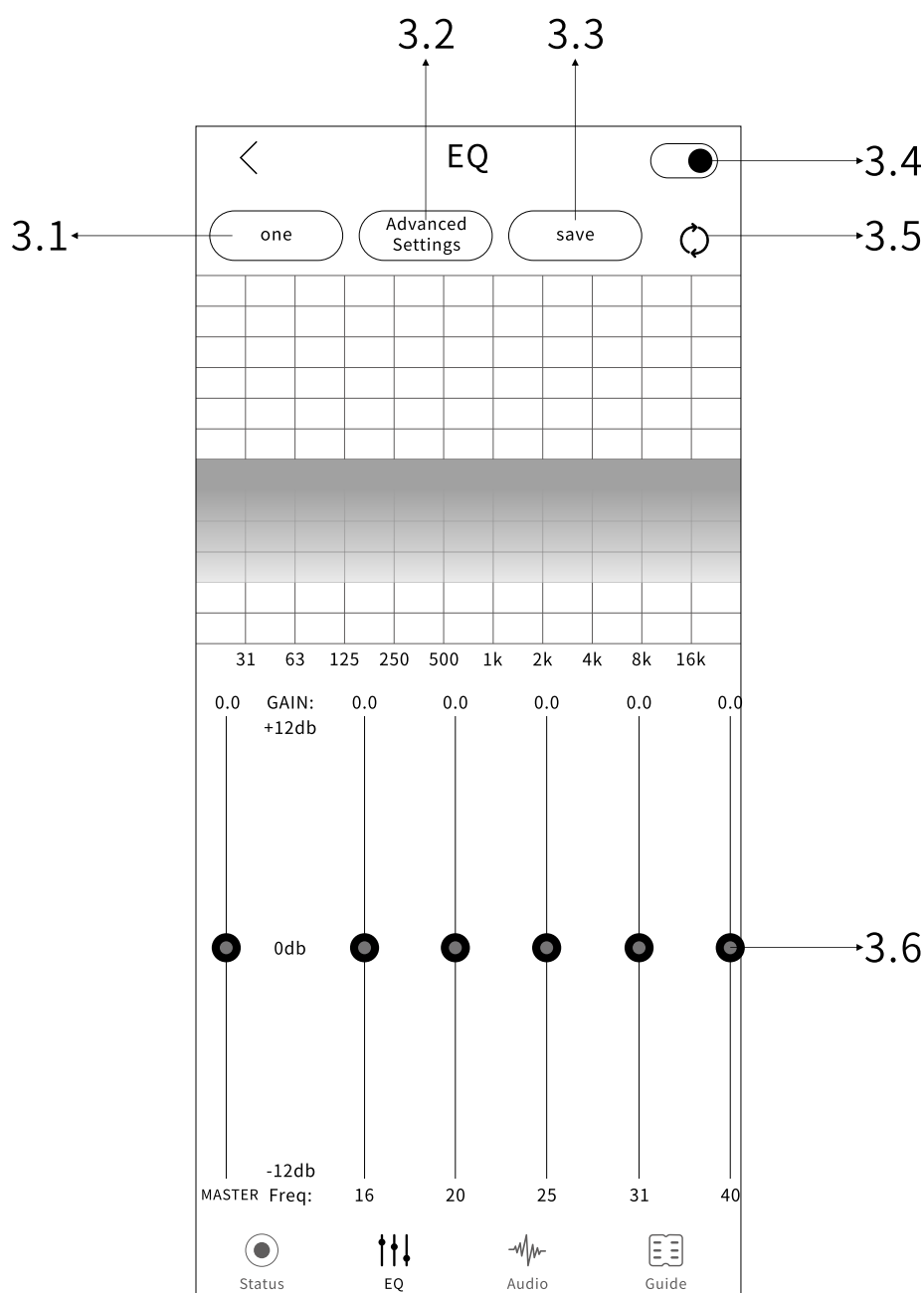

3.1 Enter the equalizer page and select different sound effects, including eight preset and three customized sound effects.

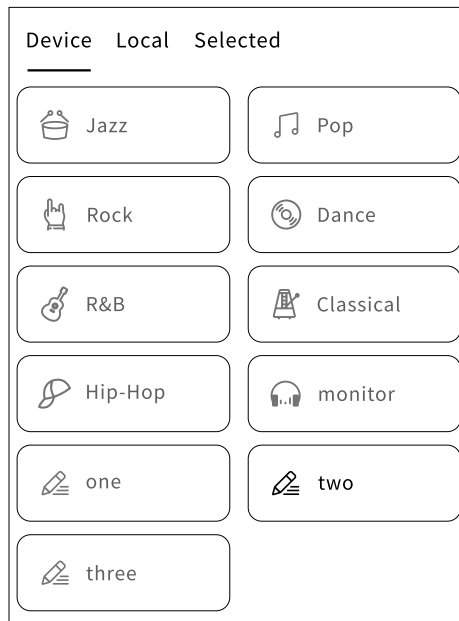

3.1.1 One, Two, and Three are customized sound effects and can be adjusted independently. The rest are preset sound effects.

3.1.2 On the local interface, customized sound effects can be saved. Logging in to the FIO account can share customized EQs with other users.

3.1.3 On the Selected EQ page, EQs from other users and official recommendations can be downloaded.

3.2 Advanced settings: customized EQ can be adjusted in more detail.

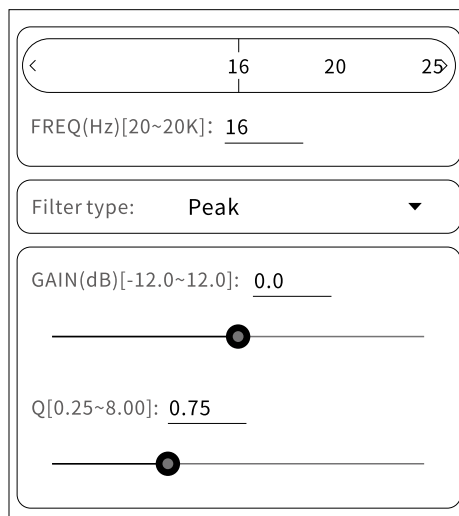

FREQ: Frequency setting, directly input the value to adjust the frequency.

Filter type: Peak - band-pass filter; LowShelf - low-pass filter, allowing low frequencies to pass through; HighShelf - High-pass filter, allowing high frequencies to pass through.

Gain: Supports -12dB to 12dB gain adjustment.

Q value: Adjust the range of bandwidth, the larger the Q value, the narrower the bandwidth.

3.3 Save, customized EQ adjustment can be saved locally.

3.4 Turn on and off EQ.

3.5 Refresh, supports refreshing through the button after customizing the EQ, all adjustments will go back to the default value.

3.6 Customize EQ, slide left and right to select different frequency points, corresponding to different frequency points; slide up and down to adjust the EQ.

Note: Pictures are for reference only. The actual product may vary.

Connection Guidance

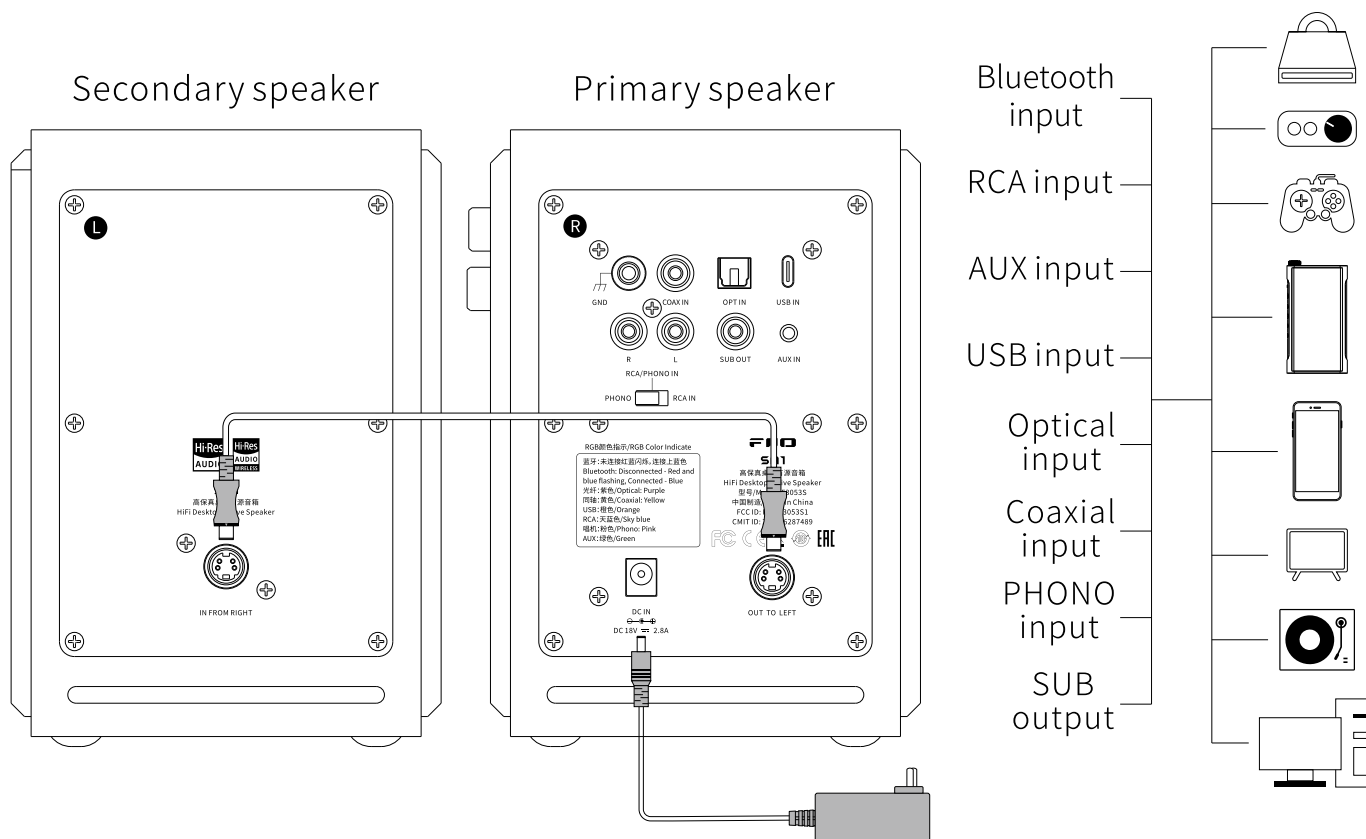

1. How to connect the primary and secondary speakers?

Connect the “Out to Left” port to the “In from Right” port through the connecting cable. Please ensure the “△” marker of the cable plug faces upwards for proper insertion and ensure the connection is in place.

2. Connection of different inputs

Switch the speakers to the corresponding input through the Input selection button. Here are instructions for connection.

(1) RCA and AUX inputs: Use the RCA to 3.5mm audio cable included in the accessory, inserting the RCA plugs into the speaker corresponding to red and white ports, and the 3.5mm plug at the other end of the cable into the appropriate port of the audio device. Or insert the 3.5mm plug into the speaker, and the RCA plugs into the appropriate output of the preamp corresponding to red and white ports.

(2) Coaxial, USB and Optical inputs: Connect to pre-stage digital devices (the connecting cable is not included).

(3) Bluetooth input: Follow the Bluetooth connection instructions to connect to devices that support Bluetooth transmission.

(4) PHONO connection: The RCA/PHONO input switch needs to be switched to “PHONO”. Note: Due to the high sensitivity of the phono input, when using the phono preamp output of a phono, please connect to the RCA input and toggle the RCA/PHONO input switch to “RCA IN”.

(5) SUB output: Please use an RCA to RCA audio cable to connect the SA1 to the input port of the active subwoofer.

3. How to connect the SA1 to a power supply?

Connect to a power adapter, insert the plug of the cable end into the “DC IN” port of the SA1, and insert the adapter plug into a corresponding outlet.

Note: Pictures are for reference only. The actual product may vary.

Placement of the Speakers

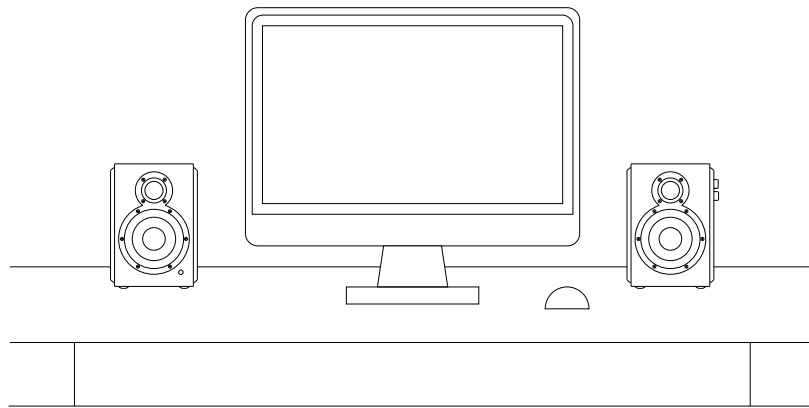

Placement of desktop speakers

When using the SA1 with a computer on a desktop, it is suggested to place the primary and secondary speakers respectively on each side of the computer monitor. The speaker back should be kept more than 20cm (≈ 8 inches) away from the wall, and the speaker side more than 40cm (≈ 16 inches). The distance between the L and R speakers should be kept at 80cm~150cm ($\approx 32\sim 60$ inches).

Based on personal listening preference, the distance between the two speakers should be adjusted according to the distance between the listener and the desktop/speaker. The farther the listener from the desktop/speaker, the farther the distance between the two speakers, forming an equilateral triangle between the two speakers and the listener.

The vertical distance between the listener and the speaker is generally between 50~100cm (20~40 inches). The listener should stay at the center of the two speakers as much as possible, and adjust the distance and placing angle of the two speakers to acquire a satisfactory stereo listening experience, reproducing the soundstage and creating a better sense of atmosphere.

Adjustment of Sound

The best sound performance can be gained by placing and adjusting the speakers correctly. Placement (as shown in Figure 1): L and R speakers face the listener and form an equilateral triangle with the listener.

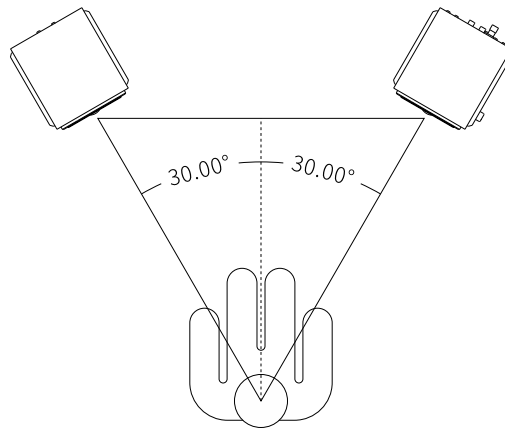
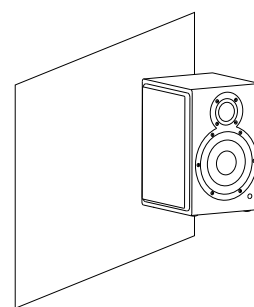

Figure1

Sound radiation space

The space where the speakers are placed is called the sound radiation space. When the sound radiation is limited by the wall, the sound pressure level will increase. Each wall around the speaker will contribute to an increase in the sound pressure level.

Ideally, freely placed speakers should have a flat frequency response curve. Placing it close to the wall will boost the bass- close to one wall, the bass will increase by 6dB; close to the included angle of two walls (or the included angle between the wall and the desk), the bass will increase by 12dB; close to the included angle between two walls and the floor (or the desk, ceiling), the bass will increase by 18dB.



Sound pressure level



Frequency

Sound pressure level

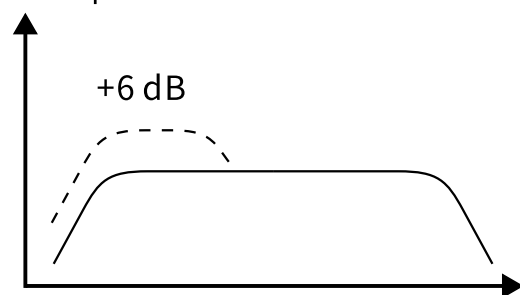

Frequency

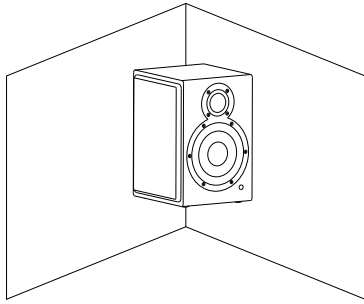

Sound pressure level

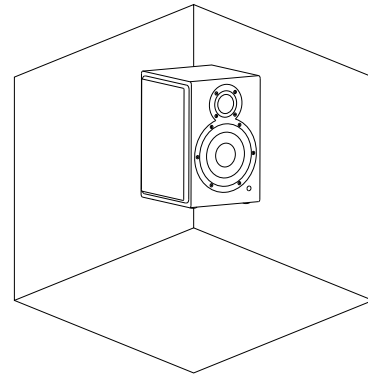
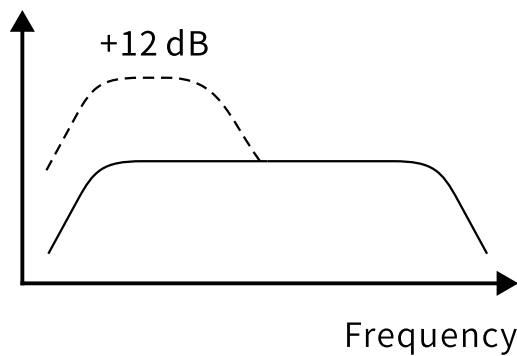

Sound pressure level

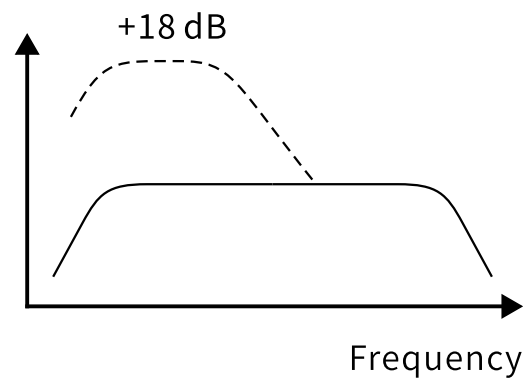

Cautions: The bass boost effect is set to the maximum by default. It can be adjusted according to different usage scenarios and desktop placement properly. If the speakers are placed against the wall or in a relatively small room, it is suggested to decrease the bass appropriately. But if they are placed in a large room or far away from the wall, the bass can be set to the maximum.

Note: Pictures are for reference only. The actual product may vary.

Notes and Precautions

1. To avoid excessively high volume causing damage to the hearing, please ensure the volume is at a low level before playing music, and adjust it to a proper level after playing.
2. If the speaker is silent during playback, please check whether the RGB light is on to tell whether the power supply is normal. At the same time, check the connection of the cable, and whether the color of the RGB light corresponds to the input source.
3. Please do not disassemble the speakers on your own. The maintenance and adjustment must be completed by personnel with professional maintenance qualifications.
4. Please do not place the speakers near water or in a humid environment. Please do not place objects filled with liquids, such as vases, on or near the speakers.
5. Please make sure the air flow behind the speaker is smooth, and do not obstruct it around the speaker.

Specifications

Speaker model	SA1
Configuration	3.5-inch woofer 0.75-inch dome tweeter
Frequency range	65Hz-20kHz
Audio input	RCA (PHONO)/AUX/OPT/COAX/BT/USB
Bluetooth codec support	LDAC/AAC/SBC
Amplifier distortion output power limit	Bass 2*20W Treble 2*5W
Bass adjustment	-6dB~0dB

Authenticity Checking

- ❶ Scratch off the coating on the product package to get a 20-bit security code.
- ❷ Go to FIIO's official website at www.fiio.com. Click the 'Check Authenticity' icon in the upper-right corner, and then enter the 20-bit security code and 4-bit verification code. You will get the checking result after clicking the 'query' icon.
- ❸ Checking results:
 - A. The security code entered proves the product is authentic.
The product you purchased is an authentic product from Guangzhou FIIO Electronics Technology Co., Ltd. Thanks for your support!
 - B. The security code entered proves the product is not authentic.
The product you purchased is not an authentic product from Guangzhou FIIO Electronics Technology Co., Ltd.

Warranty Terms and Conditions

Product types		Term of service
Main body		One month of guarantee for replacement; one year of free maintenance
Accessories except for the main body (subject to the official list)	Accessories	N/A
	Package materials (fragile parts like the packing box)	N/A

Notes: The above guarantees start from the issue date of the invoice/receipt. These warranty terms are for reference only. For specific details, please refer to the warranty terms of our local sales agents.

FIIO reserves the final interpretation and amendment for the above warranty terms and conditions.

The warranty is null and void under the following circumstances.

--Defects or damage caused by improper operations such as vibrating, bumping, falling to the ground, buckling, tearing, excessive pulling.

--Defects or damage caused by disassembly of the product by the user or unauthorized repair personnel.

--Defects or damage from being put in humid environments, places of high-intensity magnetic fields or soaked into water.

--Defects or damage caused by natural disasters.

--Unable to provide valid proof of purchase.

Note: Man-made damage should be determined by FIIO's maintenance personnel.

Procedures of Getting After-Sales Service

- ❶ Please contact the local dealer first once you find problems with the device. If they refuse to give related after-sales service, please give feedback to FIIO Support by sending an email to support@fiiio.com. We would handle it properly to ensure customers' satisfaction.
- ❷ For repair service, you are supposed to send the defective product to FIIO with freight paid. After it has been repaired, we will send the product back to you with freight paid by FIIO.
- ❸ It is highly suggested to buy the product from the local authorized sales agents so as to get better, faster before- and after-sales service.
- ❹ Please do not maintain or dismantle the product on your own and keep it away from water.
- ❺ For abnormal working issues or any further questions, please visit our official website-> Support to get related information or send an email to support@fiiio.com for consultation.

Note: Due to continuous improvement, every specification and design is subject to change at any time without further notice.

Contact Information for After-Sales Service

E-mail: support@fiiio.coms

Web: <https://www.fiiio.com>

Facebook: <https://www.facebook.com/FiiOAUDIO> & [facebook.com/fiiiosupport](https://www.facebook.com/fiiiosupport)

Scan the QR Codes Below for More Details

The SA1 supports the FIIO Control app. Scan the QR code to download it.



Internal/Supplied Batteries:

This symbol on the battery indicates that the battery is to be collected separately. This battery is designed for separate collection at an appropriate collection point.

Hereby, Guangzhou FIO Electronics Technology Co., Ltd declares that this device is in compliance with Directive 2014/53/EU. The full text of the EU declaration of conformity is available at: www.fio.com/doc

Function	Frequency	Maximum output power
Bluetooth	2402-2480MHz	3.18dBm

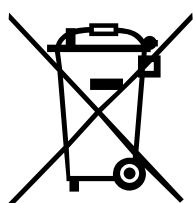
**WEEE Directive & Product Disposal**

At the end of its serviceable life, this product should not be handed as household or general waste. It should be handed over to the applicable collection point for the recycling of electrical and electronic equipment, or returned to the supplier for disposal.

Qualcomm is a trademark of Qualcomm Incorporated, registered in the United States and other countries. aptX is a trademark of Qualcomm Technologies International Ltd., registered in the United States and other countries.

**FCC NOTICE:**

This equipment has been tested and found to comply with the limits for a Class B digital device, pursuant to part 15 of the FCC Rules. These limits are designed to provide reasonable protection against harmful interference in a residential installation. This equipment generates, uses and can radiate radio frequency energy and, if not installed and used in accordance with the instructions, may cause harmful interference to radio communications.

However, there is no guarantee that interference will not occur in a particular installation. If this equipment does cause harmful interference to radio or television reception, which can be determined by turning the equipment off and on, the user is encouraged to try to correct the interference by one or more of the following measures:

- Reorient or relocate the receiving antenna.
- Increase the separation between the equipment and receiver.
- Connect the equipment into an outlet on a circuit different from that to which the receiver is connected.
- Consult the dealer or an experienced radio/TV technician for help.

This device complies with part 15 of the FCC Rules. Operation is subject to the following two conditions: (1) This device may not cause harmful interference, and (2) this device must accept any interference received, including interference that may cause undesired operation.

Any Changes or modifications not expressly approved by the party responsible for compliance could void the user's authority to operate the equipment.